



by **ENOVATION** CONTROLS



# **DF Series Hydrostatic Head Level Switches**

## ***Installation and Operations Manual***

---

00-02-0831  
2016-02-29  
Section 15

In order to consistently bring you the highest quality, full-featured products, we reserve the right to change our specifications and designs at any time. The latest version of this manual can be found at [www.fwmurphy.com](http://www.fwmurphy.com).

**Warranty** - A limited warranty on materials and workmanship is given with this Murphy product.  
A copy of the warranty may be viewed or printed by going to [www.fwmurphy.com/warranty](http://www.fwmurphy.com/warranty).



Please read the following information before installing.

**BEFORE BEGINNING INSTALLATION OF THIS MURPHY  
PRODUCT:**

Read and follow all installation instructions.

Please contact Enovation Controls immediately if you have any  
questions.

## Table of Contents

<b>Introduction</b> .....	<b>1</b>
Basic Operation.....	1
<b>Typical Applications</b> .....	<b>3</b>
Water Flood Control Systems .....	3
Typical Tank Mounting .....	3
Typical Wiring Diagrams .....	4
<b>Installation of a Volume Air Cell</b> .....	<b>5</b>
Overview .....	5
<b>Specifications</b> .....	<b>7</b>
<b>Service Parts</b> .....	<b>7</b>

**(THIS PAGE INTENTIONALLY LEFT BLANK)**

## Introduction

The DF series are diaphragm-operated hydrostatic head pressure level switches. A pressure-sensitive diaphragm operates a snap-switch that can be wired directly to electric pilot circuits to control pumps at predetermined levels. A typical application is starting and stopping electric driven pump(s) to maintain tank levels. This series of level switches can also be used with engine driven pumps.

The nitrile sensing diaphragm is impervious to most liquids and is sensitive enough to control levels with 1/4 in. (6 mm) repeatability. See the next section, **Basic Operation**, for limits of switch trip point adjustability. The case is aluminum with a glass-filled nylon bottom plate.

This is a highly reliable level switch and can be worked into almost any new or existing system without major modification or special tools.

The **DF755** and **DF757** are suitable for atmospheric tanks in non-hazardous areas. The SPDT snap-switch for the **DF755** is preset for a 4 in. (102 mm) differential in liquid level. The **DF757** trip point is adjustable over a 108 in. (2743 mm) range.

## Basic Operation

As the liquid level rises, hydrostatic head pressure is applied to the diaphragm (**A**), as shown below. The diaphragm moves upward pressing the actuator arm (**B**) to activate the snap-switch (**C**).

Model DF755 is factory set and operates at approximately 2 in. (51 mm) and 6 in. (152 mm) above the level at which the diaphragm is mounted. The trip point(s) for Model DF757 are adjustable between 2 in. (51 mm) and 110 in. (2794 mm) for high and low (make/break) operation by knobs (**D**).

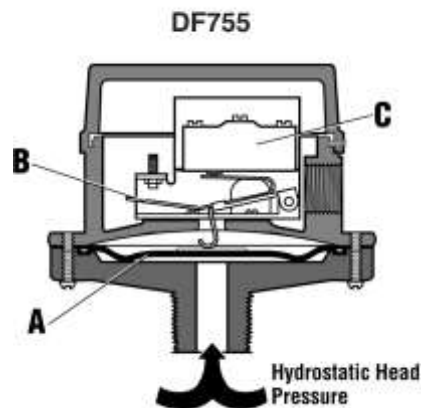

## Set Point Adjustment for the DF757

1. Locate the threaded adjustment shaft and adjustment knobs (see the following drawings).
2. To increase the low-level set point, rotate the lower knob counterclockwise.

**NOTE:** If the adjustment shaft turns when rotating the adjustment knobs, firmly grasp the adjustment shaft with a pair of needle-nose pliers and then rotate the knob.

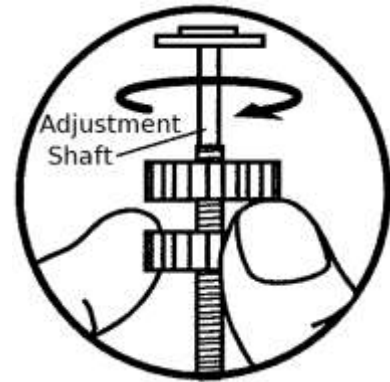
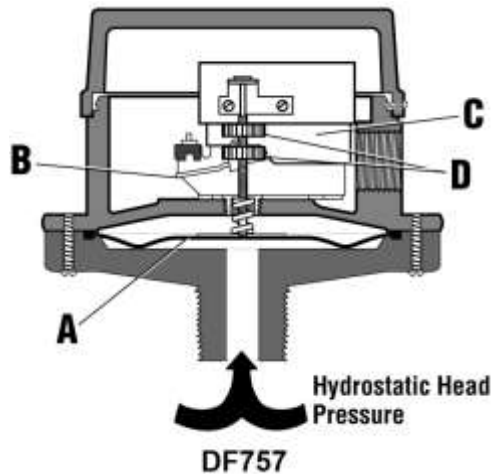

## Typical Applications

This section covers some general situations where the rugged DF Series switches provide a simple-to-install solution. Applications include:

Water Flood Systems

Crude Oil Tanks

Saltwater Disposal Systems

Diesel Day Tanks

Sumps

Cooling Towers

## Water Flood Control Systems

The diagram below displays eight DF Series switches installed on raw water and clear water tanks. When raw water rises to a predetermined level, **DF#1** stops the supply pump. As tank level falls below the set level, **DF#2** starts the supply pump. If the tank level continues to fall, **DF#3** initiates a shutdown of the supply pump. **DF#4** stops the transfer pump before the raw water tank is completely pumped out.

When clear water reaches the predetermined level, **DF#5** stops the transfer pump. As tank level falls to the set low level, **DF#6** starts the transfer pump. If the tank level continues to fall due to the failure of the filters section, **DF#7** initiates shutdown of the transfer pump. (A DF755 located at this level will also operate backwash equipment.) **DF#8** stops the injection pump before tank pumps completely out. An OPL Series Pressure SWITCHGAGE® stops the injection pump when pressure reaches an established high or low pressure.

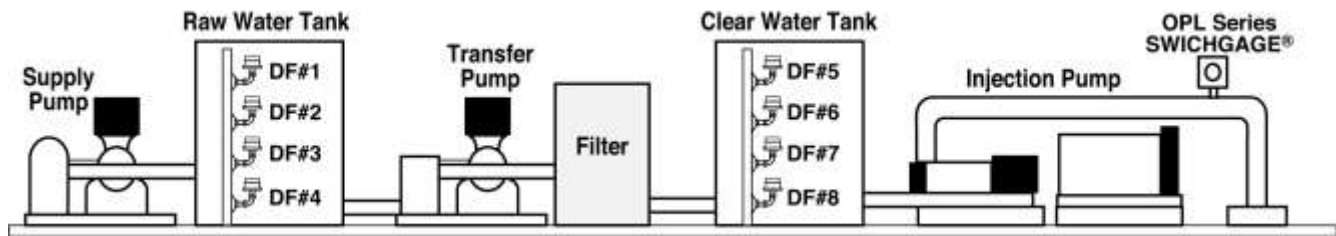

## Typical Tank Mounting

The following graphics show different methods of mounting DF755 switches in tank applications.

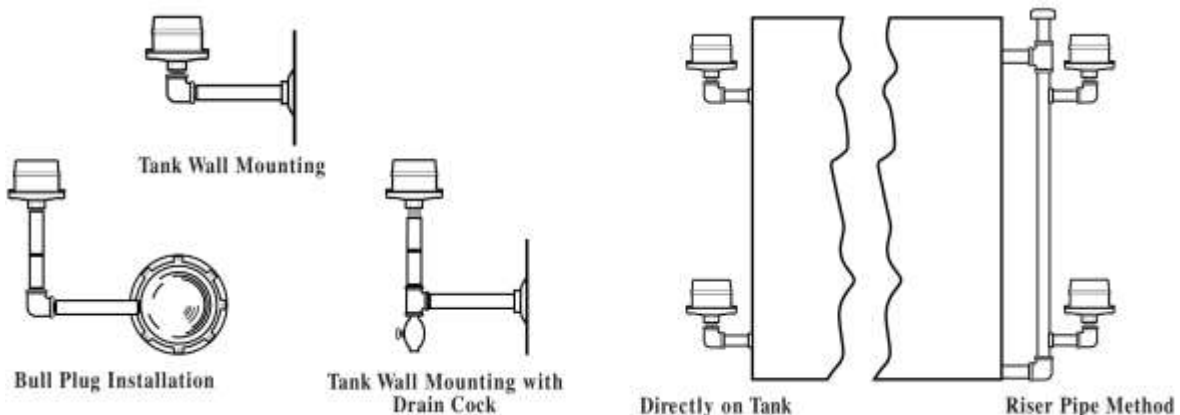

## Typical Wiring Diagrams

Presented as an assist to wiring typical DF Series level switches.

### Starts at Low Level, Stops at High

– Start motor when predetermined low level is reached and stop when high level is reached. Keeps tank level within selected limits. Motor starter is equipped with **Hands Off Auto (HOA)**.

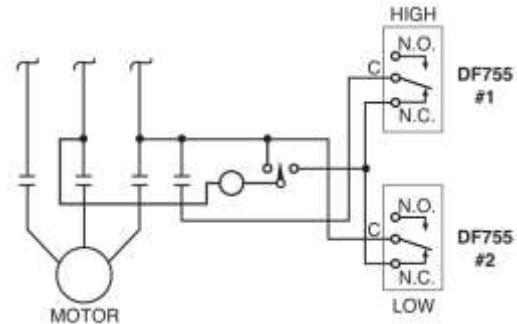

### Starts at High Level, Stops at Low

– Start motor when predetermined high level is reached and stop when low level is reached. Motor starter equipped with HOA.

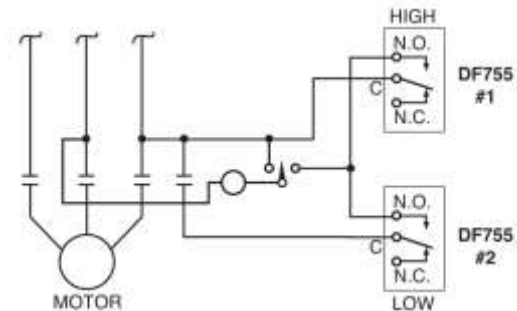

**Single Magneto Shutdown** – Wiring of magneto to Normally Open (NO) switch terminal shuts engine down at a predetermined high level (Shown at right). Wire to Normally Closed (NC) terminal to shut down on low level.

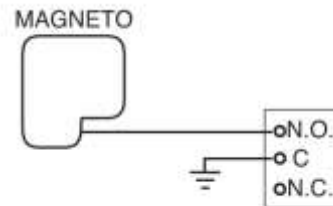

### Dual Magneto Shutdown –

Shutdown dual magneto engines using a Murphy MS2120 Magnetic Switch. Diagram at right shows hookup for low-level shutdown. Wiring changes and mounting locations are necessary for high-level shutdowns.

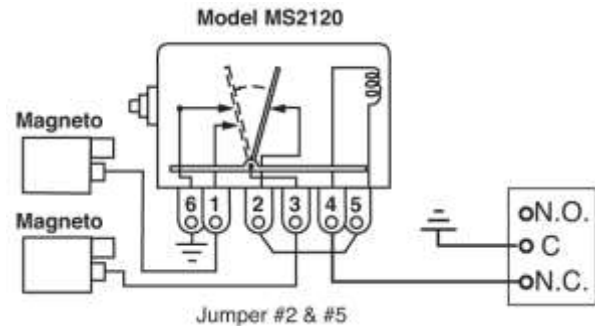



## Installation of a Volume Air Cell

This section provides installation and operation information for using a DF755 level switch with a **Murphy MAC1 Volume Air Cell**.

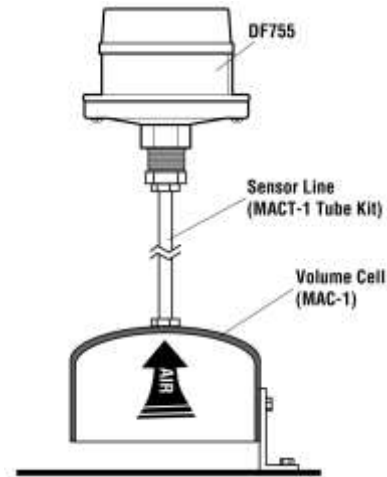

### Overview

When attached to the DF755 level switch, the **MAC1 Volume Air Cell** can monitor water levels on a sump, activate alarms or start a pump directly. The **MAC1 Volume Air Cell** is non-corrosive. Stainless steel 1/4-20 mounting studs are provided with the unit.

The **MACT1 Tubing Kit** provides 4 ft. (1.2 m) of flexible, non-corrosive 1/4 in. (6 mm) tubing (cut to fit). The kit also includes fittings necessary to attach tubing

### Volume Cell Operation

As liquid rises around the volume cell, it compresses the air inside the cell and forces it up in the sensor line. As the water level continues to rise, the air pressure increases. In time, sufficient pressure is applied to activate the internal snap-switch, which starts the pump. As the liquid level is pumped down, pressure decreases, the snap-switch reverses, and the pump stops. The pump is held in a standby condition. An air purge may be required in the sensor line. For additional information, consult Enovation Controls.

### Choosing a Volume Cell

The volume cell should be constructed of material which will be unaffected by the liquid being measured. For proper pressure to level ratio, the minimum dimensions of the volume cell should be 6 in. (152 mm) inside diameter and 3 in. (76 mm) inside depth. The sensor line can be of any diameter or material either flexible or solid, as long as it is of sufficient length to reach from the volume cell to the desired location for the DF755. All fittings and connections should be airtight to avoid loss of charge. Tube lengths longer than 4 ft. (1.2 m) should have a provision for intermittent air purging.

## Installation of the Volume Cell

Install the volume cell with reference to the level at which you wish the pump to start and stop. Secure the volume cell with a substantial bracket that will not allow the cell to float or tilt when the water level rises. Install the DF755 well above the highest water level and in a position that allows access for adjustment or repairs.

**NOTE:** Periodically operate the pump manually until the water level reaches a point approximately 1/2 in. (13 mm) below the bottom of the Volume Cell. This automatically recharges the unit and compensates for normal absorption of air into water. Small electric air pumps are available to automatically charge the system continuously.

## Specifications

### Snap-switch Ratings

#### SPDT

- 5 A @ 125, 250 or 480 VAC
- 1/2 A @ 125 VDC, 1/4 A @ 250 VDC

**Case/Lid:** Aluminum

**Bottom Plate:** Glass-filled Nylon

**Process Connection:** 1 NPT

**Maximum Pressure Rating:** 25 psi (172 kPa [1.72 Bar])

**Conduit Connection (electrical):** 1/2 NPT

**RoHS Compliant**

## Service Parts

### DF755

Description	Part Number
Cover (Aluminum)	15050081
Case (Aluminum)	15050082
Cover Screws (3), #6–32 x 5/16 Round Head	80040607
SPDT Snap-Switch and Movement Assembly/Repair Kit (5 amp)	15000122
Screws (3) for Switch Assembly to Case, #6–32 x 1/4 Round Head	80040605
Diaphragm Repair Kit	15000123
Bottom Plate (1 NPT Connection)	15050083
Bracket and Movement Repair Kit	15000313
SPDT Snap-Switch and Insulator Repair Kit (5 amp)	15000121

### DF757

Description	Part Number
Cover (Aluminum)	15050081
Case (Aluminum)	15050594
Cover Screw (3), #6–32 x 5/16 Round Head	80040607
SPDT Snap-Switch and Bracket Assembly/Repair Kit (5 amp)	15000174
Screws (2) for Switch Bracket and Assembly to Case (#6–32 x 1/4 Round Head)	80040605
Spring and Piston Assembly/Repair Kit	15000190
Diaphragm repair kit	15000123
Bottom Plate (1 NPT Connection)	15050083

In order to consistently bring you the highest quality, full-featured products, we reserve the right to change our specifications and designs at any time. MURPHY products and the Murphy logo are registered and/or common law trademarks of Enovation Controls, LLC. This document, including textual matter and illustrations, is copyright protected by Enovation Controls, LLC, with all rights reserved. (c) 2016 Enovation Controls, LLC. A copy of the warranty may be viewed or printed by going to [www.fwmurphy.com/warranty](http://www.fwmurphy.com/warranty).

**ENOVATION CONTROLS CORPORATE HEADQUARTERS**

5311 S 122ND EAST AVENUE  
TULSA, OK 74146

**ENOVATION CONTROLS – SAN ANTONIO OFFICE**

5757 FARINON DRIVE  
SAN ANTONIO, TX 78249

**ENOVATION CONTROLS – HOUSTON OFFICE**

105 RANDON DYER RD  
ROSENBERG, TX 77471

**ENOVATION CONTROLS LTD. – UNITED KINGDOM**

CHURCH ROAD LAVERSTOCK  
SALISBURY SP1 1QZ UK

**MURPHY ECONTROL TECHNOLOGIES (HANGZHOU) CO, LTD.**

77 23RD STREET  
HANGZHOU ECONOMIC & TECHNOLOGICAL DEVELOPMENT AREA  
HANGZHOU, ZHEJIANG 310018 CHINA

**U.S. SALES & SUPPORT**

**ECONTROL PRODUCTS**

PHONE: 210 495 9772  
FAX: 210 495 9791  
EMAIL: [INFO@ENOVATIONCONTROLS.COM](mailto:INFO@ENOVATIONCONTROLS.COM)  
[WWW.ECONTROL.COM](http://WWW.ECONTROL.COM)

**MURPHY PRODUCTS**

PHONE: 918 317 4100  
FAX: 918 317 4266  
EMAIL: [SALES@ENOVATIONCONTROLS.COM](mailto:SALES@ENOVATIONCONTROLS.COM)  
[WWW.FWMURPHY.COM](http://WWW.FWMURPHY.COM)

**MURPHY CONTROL SYSTEMS & SERVICES**

PHONE: 281 633 4500  
FAX: 281 633 4588  
EMAIL: [CSS-SOLUTIONS@ENOVATIONCONTROLS.COM](mailto:CSS-SOLUTIONS@ENOVATIONCONTROLS.COM)

**MURPHY INDUSTRIAL PANEL DIVISION**

PHONE: 918 317 4100  
FAX: 918 317 4124  
EMAIL: [IPSALES@ENOVATIONCONTROLS.COM](mailto:IPSALES@ENOVATIONCONTROLS.COM)

**INTERNATIONAL SALES & SUPPORT**

**UNITED KINGDOM**

PHONE: +44 1722 410055  
FAX: +44 1722 410088  
EMAIL: [SALES@ENOVATIONCONTROLS.EU](mailto:SALES@ENOVATIONCONTROLS.EU)  
[WWW.FWMURPHY.EU](http://WWW.FWMURPHY.EU)

**CHINA**

PHONE: +86 21 6237 5885  
FAX: +86 21 6237 5887  
EMAIL: [APSALES@ENOVATIONCONTROLS.COM](mailto:APSALES@ENOVATIONCONTROLS.COM)

**LATIN AMERICA & CARIBBEAN**

PHONE: 918 317 2500  
EMAIL: [LASALES@ENOVATIONCONTROLS.COM](mailto:LASALES@ENOVATIONCONTROLS.COM)

**SOUTH KOREA**

PHONE: +82 70 7951 4100  
EMAIL: [SKOREASALES@ENOVATIONCONTROLS.COM](mailto:SKOREASALES@ENOVATIONCONTROLS.COM)

**INDIA**

PHONE: +91 91581 37633  
EMAIL: [INDIASALES@ENOVATIONCONTROLS.COM](mailto:INDIASALES@ENOVATIONCONTROLS.COM)



FM 28221 (Tulsa, OK - USA)  
FM 626667 (San Antonio, TX - USA)  
FM 28221 (Rosenberg, TX - USA)  
FM 29422 (UK)



FM 323851 (China) TS 589322 (China)